

CBCS SCHEME



USN

--	--	--	--	--	--	--	--	--	--

17EC563

Fifth Semester B.E. Degree Examination, Aug./Sept.2020 8051 Microcontroller

Time: 3 hrs.

Max. Marks: 100

Note: Answer any FIVE full questions, choosing ONE full question from each module.

Module-1

- 1 a. Explain the architecture of 8051 with necessary diagram. (08 Marks)
- b. Write the internal RAM division of 8051 and explain how it can be used. (06 Marks)
- c. Compare microprocessor with microcontroller. (06 Marks)

OR

- 2 a. Draw the diagram to show how 4K ROM and 8K RAM can be interfaced to 8051 microcontroller and explain. (08 Marks)
- b. Explain the PSW of 8051 microcontroller. (06 Marks)
- c. Mention the alternate functions of PORT 3 in 8051 microcontroller. (06 Marks)

Module-2

- 3 a. Mention the four addressing modes used in 8051 microcontroller and explain each one of them with an example. (08 Marks)
- b. What is bit level logical operation and explain the bit level instructions which affect the carry flag. (06 Marks)
- c. Write an assembly level program to add two numbers present in external memory location 8000h and 9000h of 8051 microcontroller store the 16 bit result obtained in reg A and B with MSB of the result in reg A. (06 Marks)

OR

- 4 a. Draw a figure to indicate the relative range of all the jump instructions. Also explain bit jump instruction present in 8051 microcontroller. (08 Marks)
- b. Explain rotate instructions available in 8051 micro controller with an example to understand its working. (06 Marks)
- c. Write a program to exchange the contents of reg.R0 in bank0 with the contents of reg.R5 in bank2 using PUSH and POP instructions. Assume that the SP is starting from 20h. (06 Marks)

Module-3

- 5 a. What is the use of stack in 8051 microcontroller and explain the instructions used to move and retrieve the data from stack with an example. (06 Marks)
- b. Find the time required to execute the following instructions using 8051 microcontroller.
 - (i) MOUR3, #55; crystal frequency is 11.0592 MHz
 - (ii) DJN2 R2, target; crystal frequency is 20 MHz
 - (iii) MULAB; crystal frequency is 16 MHz (06 Marks)
- c. Write an assembly level program for 8051 microcontroller to find the factorial of an 8 bit number. Assume the result obtained in maximum of 8 bits only. (08 Marks)

OR

- 6 a. Write the sequence of events that happens on execution of CALL and RET instructions with necessary diagram. **(06 Marks)**
- b. A switch is connected to microcontroller 8051 as shown in Fig.Q6(b). If switch is closed then switch on LED1 else switch on LED2. Write a program for the above requirement. Glow the LED for 100 μ s XTAL = 11.0592 MHz.

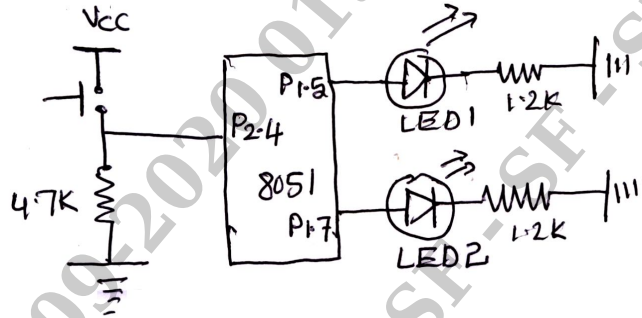

Fig.Q6(b)

- c. Write an assembly level program to find the smallest of the 05 numbers stored in consecutive memory location in internal RAM starting from 100 h and store the result in accumulator. **(08 Marks)**

Module-4

- 7 a. Indicate the bits present in TMOD register and explain its uses. **(06 Marks)**
- b. Write the steps to program in MODE2 timer 01. Also find the frequency of square wave generated with duty cycle of 50% if TH1 is set to 05 when used in timer0 in mode 2. Given XTAL = 11.0592 MHz. **(06 Marks)**
- c. Write an assembly level program to generate a square wave on P_{1,2} with 50% duty cycle. Find the frequency of the square wave generated if timer0 is used in MODE1 in the above program if TH0 = 00 and TL0 = 00 and also the crystal frequency used is 11.0592 MHz. **(08 Marks)**

OR

- 8 a. Indicate the bits present in SCON register and explain its uses. **(06 Marks)**
- b. Write the steps used to transfer the data serially in 8051 microcontroller. **(06 Marks)**
- c. Write an 8051 program to transfer the message "VTU" serially at 9600 baud, 8 bit data continuously. **(08 Marks)**

Module-5

- 9 a. Explain IE register and TCON register of 8051 microcontroller. **(06 Marks)**
- b. List the interrupt priority upon reset on 8051 microcontroller and how the highest priority can be given to serial communication after reset. **(06 Marks)**
- c. Write a program to generate a square wave of 50 Hz on P_{1,2} using interrupt with 50% duty cycle. Assume XTAL = 11.0592 MHz. **(08 Marks)**

OR

- 10 a. Explain the various pins present in ADC0804. **(10 Marks)**
- b. Write the various pins present in LCD and also indicate how LCD can be interfaced to 8051 microcontroller to check the status of the busy flag. **(10 Marks)**
